

MH 311 105

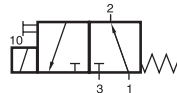

MOH 311 105

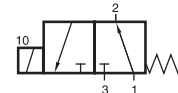

MX 311 105

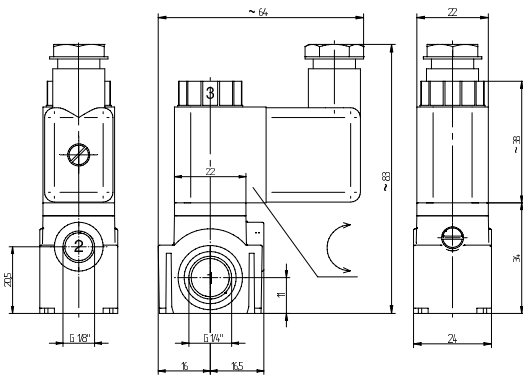

MH 311 105/MOH 311 105

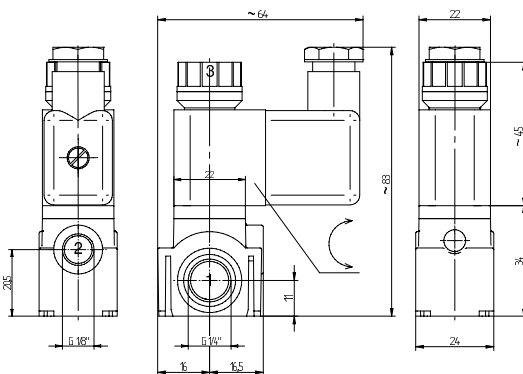

MX 311 105



Direct acting 3/2-way solenoid valve, equipped with mechanical spring return, body made from polyamide.

Type MH 311 105

Normally closed, port 1 in the body, including manual override

Type MOH 311 105

Normally open, port 1 at the top of the solenoid, including manual override

Type MX 311 105

Normally open, port 1 in the body, no manual override

Individual valves can easily be combined to manifold systems just by putting 2 brass brackets (type VBM 105) into the bodies from the bottom. MH and MX valves can be combined in the same manifold system.

By closing port 3 valves can be turned into 2/2-way valves.

Available with solenoid operators:
230V/50Hz, 110V/50Hz, 24V/50Hz, 48V=, 24V=, 12V=.

Valves can be used for technical vacuum too.

Available and useful accessories:

KV SET 01

Set to connect two valves consisting of two brass clamping brackets and a NBR O-ring.

3015 – 1/4

Plug to close one side of the two supply ports in the valve, brass, nickel plated G1/4" with O-ring seal.

Type	Function	Port size			Air flow	Operating pressure	Power consumption	Weight
		1	2	3				
MH 311 105	n.c.	G 1/4"	G 1/8"	M5	60 l/min	-0,9 - 10 bar	3 W= / 5 VA	0,09 kg
MOH 311 105	n.o.	M5	G 1/8"	G 1/4"	60 l/min	-0,9 - 10 bar	3 W= / 5 VA	0,09 kg
MX 311 105	n.o.	G 1/4"	G 1/8"	hole	60 l/min	-0,9 - 8 bar	3 W= / 5 VA	0,09 kg