

**Art: 3038**  
**Válvula de esfera M-H. Paso total**  
**Brass ball valve M-F. Full bore**

### Características

1. Válvula esfera PN-25, paso total.
2. Construcción en latón según UNE-EN 12165.
3. Extremos rosca gas (BSP) macho-hembra según ISO 228/1.
4. Accionamiento mediante palomilla roja (indicador agua caliente).
5. Temperatura máxima 180 °C.

### Features

1. Ball valve PN-25, full bore.
2. Brass according to UNE-EN 12165.
3. Threaded ends gas (BSP) male-female according to ISO 228/1.
4. Working by means of red T-handle (hot water indicator).
5. Max. Temperature 180 °C.

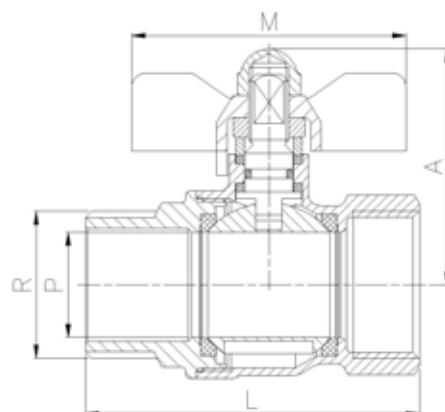
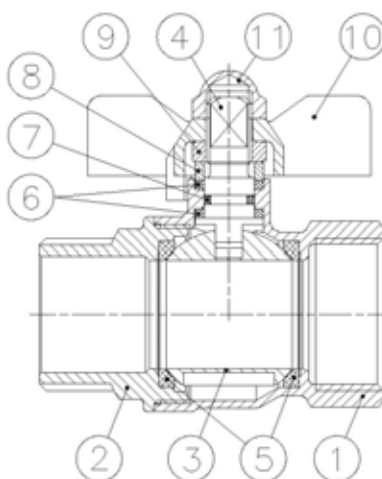

Nº	Denominación / Name	Material	Acabado Superficial / Surface Treatment
1	Cuerpo / Body	Latón / Brass (CW617N)	Granallado + Cromado / Peened + Chromed
2	Tapa / Cap	Latón / Brass (CW617N)	Granallado + Cromado / Peened + Chromed
3	Esfera / Ball	Latón / Brass (CW617N)	Cromado / Chromed
4	Eje / Stem	Latón / Brass (CW614N)	Cromado / Chromed
5	Asientos / Ball seats	PTFE	-
6	Anillo junta / Stem packing	PTFE	-
7	Junat tórica / O-Ring	NBR	-
8	Anillo prensa / Stem ring	Latón / Brass (CW614N)	Cromado / Chromed
9	Tuerca / Nut	Latón / Brass (CW614N)	Cromado / Chromed
10	Maneta / T-Handle	Aluminio / Aluminium	Pintado / Painted
11	Tuerca / Nut	Latón / Brass (CW614N)	Cromado / Chromed

Ref.	Medida / Size	DN	Dimensiones / Dimensions (mm)				Peso / Weight (g)
	R		P	A	L	M	
3036 02	1/4"	10	10	38	48	50	100
3036 03	3/8"	10	10	38	49	50	105
3036 04	1/2"	15	14	40	56	50	150
3036 05	3/4"	20	19	50	64	62	250
3036 06	1"	25	24	53	76	62	380