

ARTICULO: 2525

Válvula de esfera paso total Bridada, Fund. Nodular Ductile Iron full port ball valve, Flanged ends

Características

1. Válvula de esfera paso total, 2 piezas.
2. Extremos bridados según EN 1092 PN16.
3. Construcción en EN-GJS-400 (GGG-40).
4. Longitud entre caras según EN 558 serie 27
5. Asientos PTFE + 15 % F.V.
(otro material consultar)
6. Esfera y eje Inoxidable AISI 304.
7. Tórica en el eje de FKM (Viton).
8. Vástago expulso.
9. Montaje directo para actuadores s/ ISO 5211.
10. Dispositivo de Bloqueo de Seguridad.
11. Presión de trabajo máxima 16 bar.
12. Temperatura de trabajo -30 °C + 180 °C.

Features

1. Full port ball valve, 2 pieces.
2. Flanged ends according to EN 1092 PN16.
3. Made of Ductile Iron EN-GJS-400 (GGG-40).
4. Face to Face according to EN 558 series 27.
5. Ball seats PTFE + 15 % FG
(please ask for other materials)
6. Ball and Stem made of AISI 304.
7. O'ring in the stem FKM (Viton).
8. Blow-out proof stem.
9. Direct Mounting for actuator acc. to ISO 5211.
10. Block System.
11. Max. Working pressure 16 bar.
12. Working Temperature -30 °C + 180 °C.

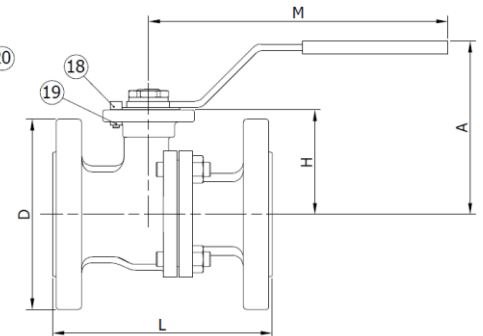
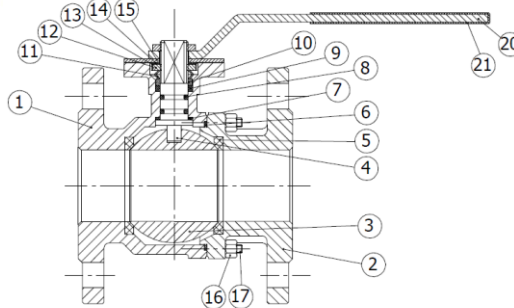

Nº	Denominación / Name	Material	Acabado Superficial / Surface Treatment	Cód. Recambio Spare Part Code
1	Cuerpo / Body	Fund. Nodular / Ductile Iron EN-GJS-400	Pintado exterior / Painted outside	-----
2	Tapa / Cap	Fund. Nodular / Ductile Iron EN-GJS-400	Pintado exterior / Painted outside	-----
3	Bola / Ball	Acero Inoxidable / Stainless Steel 1.4308	Pulido / Polished	-----
4	Eje / Stem	Acero Inoxidable / Stainless Steel AISI 304	-----	-----
5*	Asiento / Ball seat	PTFE + 15% F.V. / PTFE + 15% FG	-----	2825
6*	Junta / Gasket	PTFE	-----	2825
7*	Arandela / Thrust Washer	PTFE	-----	2825
8*	Tórica / O' ring	FKM	-----	2825
9*	Empaquetadura / Stem packing	PTFE	-----	2825
10	Anillo Prensa / Gland	Acero Inoxidable / Stainless Steel AISI 304	-----	-----
11	Arandela / Spring Washer	Acero Inoxidable / Stainless Steel AISI 301	-----	-----
12	Tuerca / Nut	Acero Inoxidable / Stainless Steel AISI 304	-----	-----

13	Antigiro / Lock Washer	Acero Inoxidable / Stainless Steel AISI 304	-----	-----
14	Arandela / Washer	Acero Inoxidable / Stainless Steel AISI 304	-----	-----
15	Placa Tope / Stop plate	Acero Inoxidable / Stainless Steel AISI 304	-----	-----
16	Perno / Stud Bolt	Acero Inoxidable / Stainless Steel AISI 304	-----	-----
17	Tuerca / Nut	Acero Inoxidable / Stainless Steel AISI 304	-----	-----
18	Pin tope / Stopper pin	Acero Inoxidable / Stainless Steel AISI 304	-----	-----
19	Tuerca / Nut	Acero Inoxidable / Stainless Steel AISI 304	-----	-----
20	Maneta / Handle	Acero al Carbono / Carbon Steel	Zincado / Zinc Plated	-----
21	Funda maneta / Handle sleeve	Vinilo / Vynil	-----	-----
22	Soporte maneta / Handle support	Acero al Carbono / Carbon Steel	Zincado / Zinc Plated	-----
23	Retén / Retainer	Acero Inoxidable / Stainless Steel AISI 304	-----	-----

* Piezas de recambio disponibles / Available spare parts

Detalle maneta DN200 (8") / Handle detail size DN200 (8")

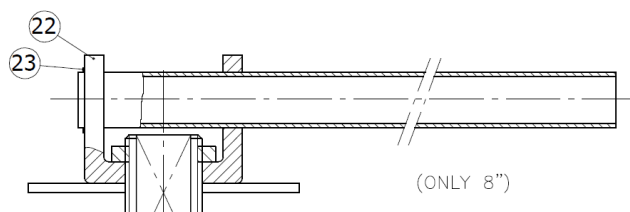

DIMENSIONES GENERALES / GENERAL DIMENSIONS

Ref.	Medida Size	PN	Dimensiones / Dimensions (mm)							ISO 5211	Peso / Weight (Kg)
			D	A	L	M	H	CxC	h		
2525 04	1/2"	16	95	80	115	130	50	9x9	9,5	F03/F04	2,300
2525 05	3/4"	16	105	80	120	130	55	9x9	9,5	F03/F04	2,800
2525 06	1"	16	115	90	125	170	60	11x11	11,5	F04/F05	4,100
2525 07	1 ¼"	16	140	102	130	170	74	11x11	11,5	F04/F05	5,400
2525 08	1 ½"	16	150	110	140	220	78	14x14	15,5	F05/F07	6,900
2525 09	2"	16	165	120	150	220	86	14x14	15,5	F05/F07	9,300
2525 10	2 ½"	16	185	140	170	284	98	17x17	18,5	F07/F10	14,000
2525 11	3"	16	200	150	180	284	114	17x17	18,5	F07/F10	18,300
2525 12	4"	16	220	180	190	360	136	17x17	18,5	F07/F10	25,300
2525 13	5"	16	250	215	325	447	165	17x17	18,5	F07/F10	37,000
2525 14	6"	16	285	240	350	560	190	22x22	23	F10/F12	49,500
2525 16	8"	16	340	320	400	850	229	27x27	25	F12/F14	98,000

Detalle de la zona de Eje / *Stem detail*

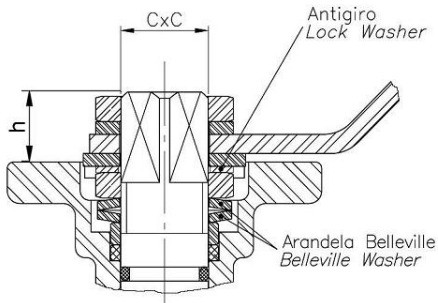

Antigiro / *Lock Washer*: Previene el desajuste de la tuerca del eje en elevados ciclos de maniobra / *Prevents unthreading of stem nut in high cycle automation applications.*

Arandela Belleville / *Belleville Washer*: Las arandelas belleville proporcionan una carga constante sobre el prensa asegurando un cierre firme en variaciones de condiciones de trabajo. / *Standard belleville washers provide constant "live load" on the stem seals, assuring a tight seal even varying service parameters.*

CURVA PRESION TEMPERATURA / *PRESSURE TEMPERATURE RATING*

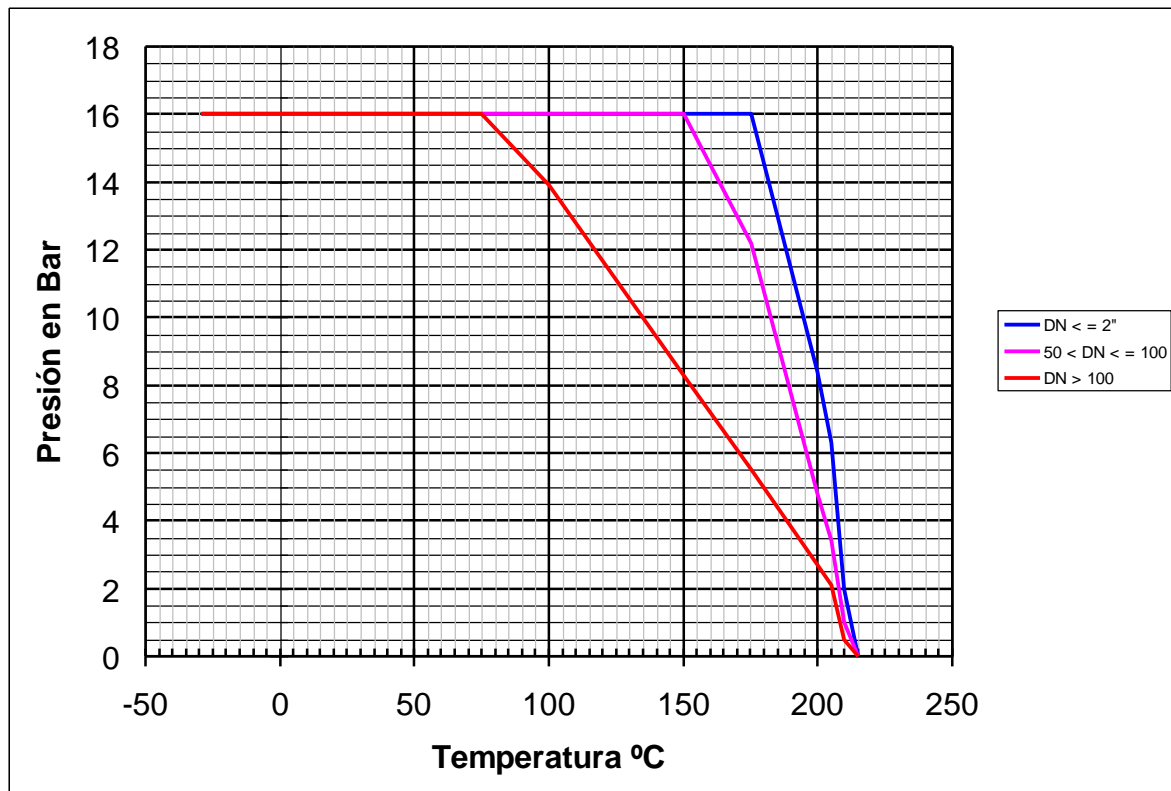

VALORES DE Kv / Kv VALUES

Kv = Es la cantidad de metros cúbicos por hora (m^3/h) que pasará a través de la válvula generando una pérdida de carga de 1 bar.

Kv = Flow rate of water in cubic meter per hour (m^3/h) that will generate a pressure drop of 1 bar across the valve.

1/2"	3/4"	1"	1 1/4"	1 1/2"	2"	2 1/2"	3"	4"	5"	6"	8"
19	40	65	110	180	365	495	970	1620	2530	4050	8650

