

LP1116-D

VACUUMPUMP LOWVOLTAGE



aimspump

Typical performance

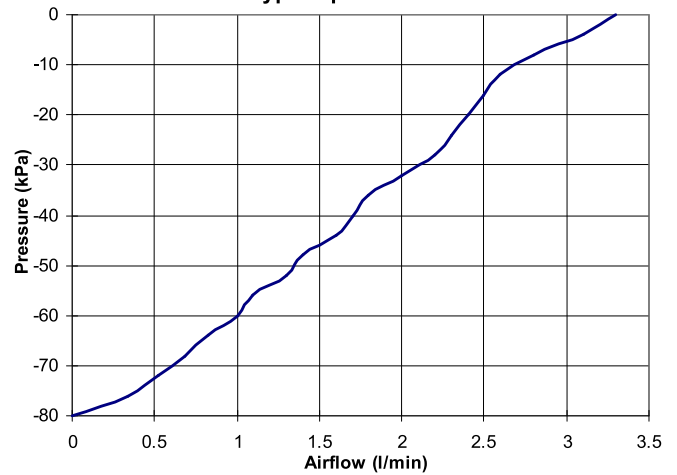

LP1116-D SPECIFICATIONS

Rated Voltage(s):	DC 12 Volts
Rated Vacuum:	44kPa
Maximum Vacuum Airflow:	>3 l/min
Maximum Vacuum:	>-80kPa
Power Consumption Max (DC):	24 VA
Duty Cycle:	Continuous
Coil insulation Class:	Class F
Environmental Conditions:	0°C – 40°C & 35% - 85% RH
Mounting Dimensions:	75(L) x 62(W) mm
Unit outside dimensions:	126mm x 58mm x 58mm
Gross Weight:	795 grams (1.75lbs)
Lead Wire Length:*	AWG22 (UL1015, 105°C) X 150mm
Outlet:*	7.5mm diameter barb, hose nipple.

This pump has an integral drive circuit. Connect to a suitable 12V DC supply. Red to positive, black to negative. Please observe correct polarity. Failure to do so will result in damage to the pump.

*Example given. Customer determined attributes are available.

Patented and patents pending.

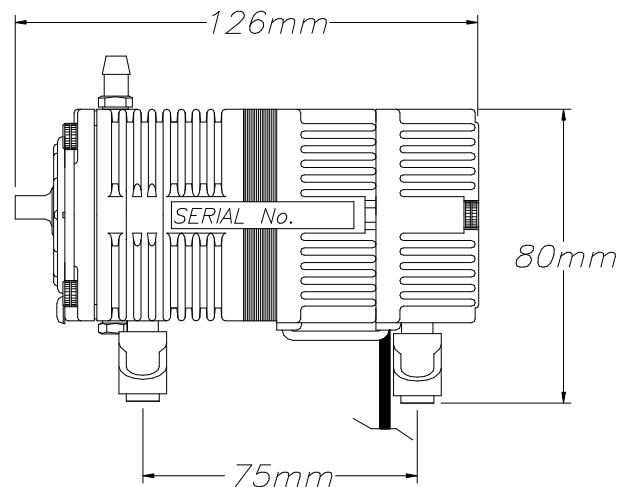
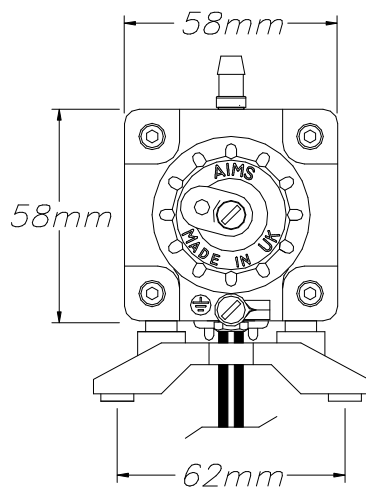

Contact technical sales for additional information regarding life expectancy and operating conditions.
All the information in this datasheet is supplied in good faith.
This information is given without obligation or liability.