

AC1011

AIRCOMPRESSOR



aimspump

Typical performance

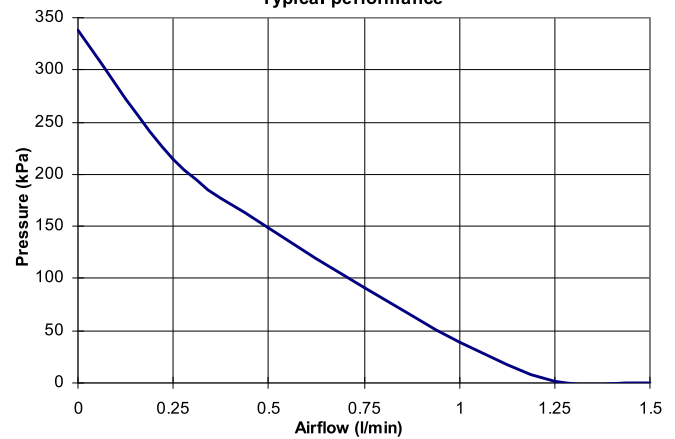

AC1011 SPECIFICATIONS

Rated Pressure:	150kPa
Rated Airflow:	0.5 l/min
Rated Voltage(s):	230V
Maximum Pressure:	>300kPa
Rated Frequency:	50Hz
Power Consumption:	17 to 20W
Duty Cycle:	Continuous
Coil insulation Class:	Class F
Environmental Conditions:	0°C – 40°C & 35% - 85% RH
Mounting Dimensions:	48(L) x 62(W) mm
Unit outside dimensions:	90mm x 58mm x 58mm
Gross Weight:	700 grams (1.54lbs)
Lead Wire Length:*	AWG22 (UL1015, 105°C) X 260mm
Outlet:*	4mm hose elbow adaptor

*Example given. Customer determined attributes are available.
Patented and patents pending

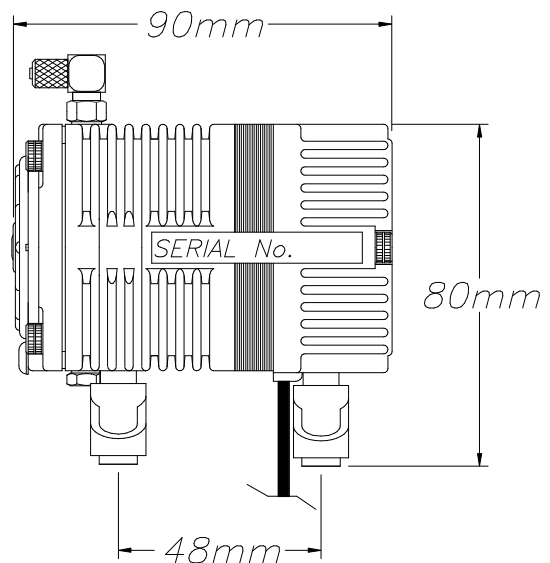
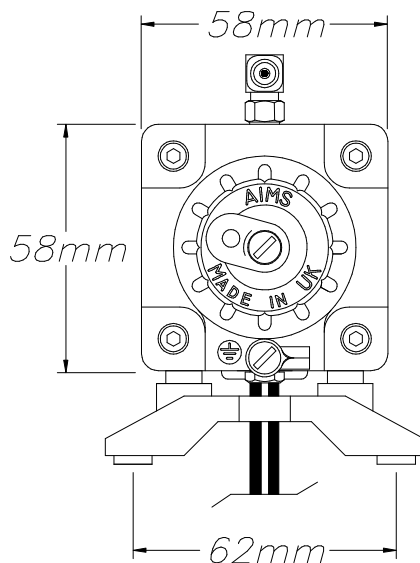

Contact technical sales for additional information regarding life expectancy and operating conditions.
All the information in this datasheet is supplied in good faith.
This information is given without obligation or liability.