

DESCRIPTION

Solenoid valve 2 way normally open with servo-assisted diaphragm

CONSTRUCTION

Body and cover	Brass
Armature tube	AISI 303
Plunger and core	AISI 430FR
Springs	AISI 302
Seal material	NBR - FPM - EPDM



FEATURES

- Minimum differential pressure 0.15bar
- Maximum allowable pressure PS 25bar^③
- Maximum fluid viscosity 25cSt (mm²/s)
- Ambient temperature: from -10°C to +80°C according to the coil
- Preferred mounting position with vertical coil above

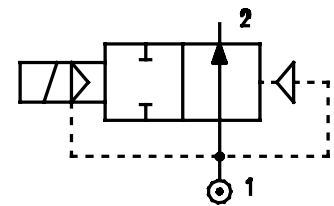

4

- OPTIONS:**
- Electroless nickel plating
 - Series 7 explosion proof coil according to ATEX - EExmII
 - us certified coils

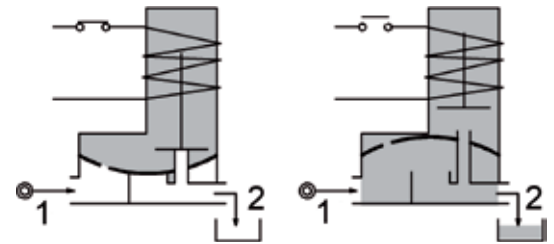

ON REQUEST: Manual override

CODE ① ②	Connection G ISO 228	Orifice mm	Kv m ³ /h	Differential pressure bar			Nominal power			Coil		Seal ①	Temp. range °C
				Min	Max		AC Inrush	VA Holding	DC Watt	Series	Width		
E207B...10///...	1/4"	10	1.5	0.15	15	15						NBR=B	-10 +90
E207C...10///...	3/8"	10	1.7	0.15	15	15							
E207C...12///...	3/8"	12	2.2	0.15	15	15							
E207D...12///...	1/2"	12	2.5	0.15	15	15	12	8	6.5	3	22	EPDM=E	-10 +140
E207E...18///...	3/4"	18	5.5	0.15	13	13							
E207F...25///...	1"	25	10.2	0.15	10	10							
E207G...30///...	1" 1/4	30	15	0.15	10	10						FPM=V	-10 +140

① Seal
 ② Coil
 Example: E207DB12///301 NBR seal
 Coil 24V DC

③ **REMARK**
 The maximum allowable pressure PS for steam 2,5bar (gauge pressure)

COILS	Alternating Current 50/60Hz (V)							Direct Current (V)			Electrical connection	Connectors
	12	24	48	110	220 230	240	380	12	24	48		
Series 3 Width 22 Code ②	30A	30B	30C	30D	30E	30F	30G	300	301	302	DIN 46244	PG9 code 10348000

DESCRIPTION
 Class F insulation
 Voltage tolerance
 AC +15% -10%
 DC ± 10%
 Protection class
 IP65 with connector fitted
 IP00 without connector
 Continuous service ED100%

OPTIONS
 Class H insulation
 Cable attached
 Special coil voltage
 Special coil powers
 cULus certified coils

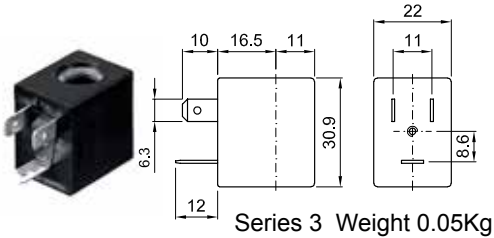

(for more details see section 8)

SPARE PARTS LIST

1. Coil fixing nut
2. Coil
3. Seal assembly
4. Armature tube with core
5. Diaphragm assembly

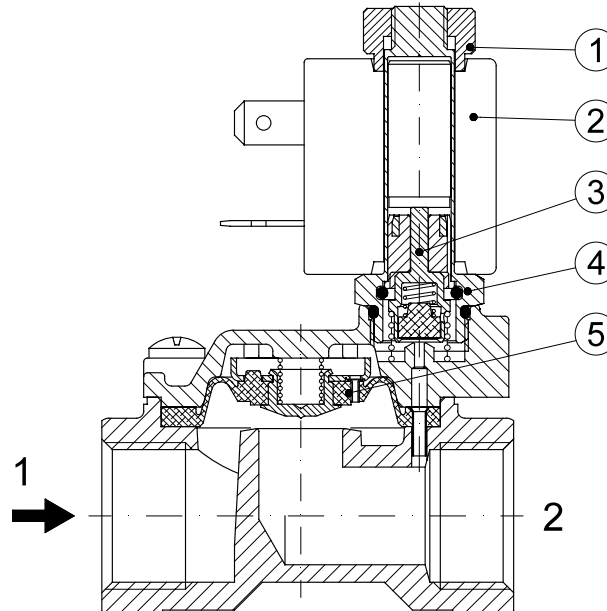

OVERALL DIMENSION

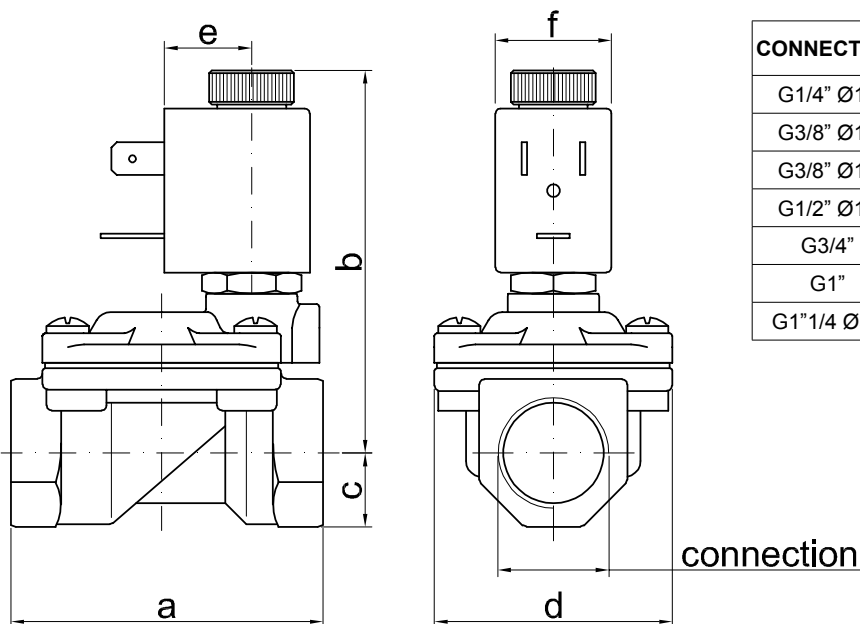

CONNECTION	a	b	c	d	e	f	weight Kg
G1/4" Ø10	49	65	11	32	16	22	0.23
G3/8" Ø10	49	65	11	32	16	22	0.24
G3/8" Ø12	59	73	14	45	16	22	0.42
G1/2" Ø12	59	73	14	45	16	22	0.39
G3/4"	79	76	18	55	16	22	0.65
G1"	96	85	20	72	16	22	1.05
G1"1/4 Ø30	119	96	25	85	16	22	1.70